

Design of Microwave Chebyshev band pass filters for frequency band from 1-5 GHz

Sanjay Mishra¹, Agya Mishra²

^{1,2}Department of Electronics and Communication Engineering
Jabalpur Engineering College, Jabalpur (M.P.), India

Abstract

This paper presents design method of the Chebyshev band pass filter for particularly microwave frequency range. The study involves circuit analysis to determine generalized Chebyshev responses with a transmission zero at finite frequency in order to produce a reduced number of elements values of prototype circuit. An exact synthesis and design procedure has been discussed for a calculation of S-Parameter insertion loss and return loss.

Keywords: Microwave filter, chebyshev band pass filter, band pass filter(BPF), insertion loss(IL), return loss(RL).

1. Introduction

With the fast development of wideband wireless communication, BPF with characteristics of high performance, low-cost, low insertion loss (IL) and compact BPF are highly desirable. For the next generation of wireless communication system, the planar microwave bandpass filters (BPFs) are an essential component in many communication systems. [1] The simplest resonator structure that can be used in radio frequency and microwave filters is an LC tank circuit consisting of parallel or series inductors and capacitors. These have the advantage of being very compact, but the low quality factor of the resonators leads to relatively poor performance.

Chebyshev filters are used to separate one band of frequencies from another. Although they cannot match the performance of the filter, they are more than adequate for many applications. The primary attribute of Chebyshev filters is their speed, typically more than an order of magnitude faster than the other filter. This is because they are carried out by recursion rather than convolution. The design of these filters is based on a mathematical technique called the z-transform. This presents the information needed to use Chebyshev filters

without wading through a mire of advanced mathematics. It is very important to

reduce the losses like an insertion loss and return loss in various communication. [10]

Microwave filters are vital components which provide frequency selectivity in wide variety of electronic systems, including mobile and satellite communications, radar, electronic warfare, and remote sensing systems operating at microwave frequencies. Type of the filter is defined with frequency, which it allows to pass or reject. Lowpass, highpass, bandpass and bandstop filters with different topologies exist to perform frequency selectivity. [13]

Microwave bandpass filters (BPFs) are an essential component in many communication systems. To develop dual-band operation systems, a planar type of dual-band BPFs have been intensively researched recently. One of the direct design methods for the dual-band BPFs is to parallel connect two single-band BPFs. In two monolithic narrowband BPFs with different center frequencies are parallel connected by dual-band impedance matching networks. Thus, each single-band BPF is responsible for filtering one passband. [3]

Chebyshev filters are analog or digital filters having a steeper roll-off and more passband ripple (type I) or stopband ripple (type II) than Butterworth. Chebyshev filters have the property that they minimize the error between the idealized and the actual filter characteristic over the range of the filter but with ripples in the passband. This type of filter is named after Chebyshev because its mathematical characteristics are derived from Chebyshev polynomials. Because of the passband ripple inherent in Chebyshev filters, the ones that have a smoother response in the pass band but a more irregular response in the stop band are preferred for some applications [14].

2. Theory of chebyshev bandpass filter

2.1 Fundamentals and Design of LC passive bandpass filters

In general, electrical performances of a filter are described in terms of the insertion loss (IL), the return loss (RL), a frequency-selectivity (attenuation at rejection band), the group-delay variation in the passband, and so on. Filters are required to have: small losses in the transmitted power (IL); a large reduction of the reflected energy (RL) in a passband for proper impedance matching with interconnecting components and a high frequency-selectivity to prevent any interference. In the mechanical performance aspect, filters are needed to have small volume, mass and good temperature stability [11]. In cost and space parameters, the filter order (quantity of LC resonators) has a considerable influence.

There are two methods of filter design. One is known as the image parameter method. The second is known as the polynomial method or insertion loss method [7]. In the insertion loss method, a filter response is defined by a transfer function which is the ratio of the output voltage to the input voltage of a filter and the goal is to minimize the mismatch between the load and source resistors.

A second way to describe control of filter parameters is by the scattering matrix, if a filter performs as the two-port network. Incident currents and voltages in both ports transformed to vectors *a* and *b* which have the transfer matrix *S*. Components of this matrix relate to a measured transmission and a reflection through a network and are called scattered parameters [5].

Ideal filter would have no insertion loss and a linear phase response in the passband, an infinite attenuation in the stopband and matched at the input and output. It is impossible to practically build such a filter, therefore compromises must be made. Design by insertion loss method, allows a high degree of control over the filter width, stopband slope and phase characteristic. Depend on the application; the necessary trade off design can be evaluated [8].

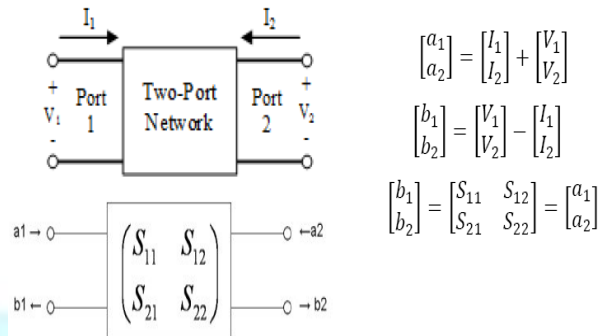

Fig. 1. Two-port network and the scattering matrix [S].

Therefore, a filter response closed to ideal (Fig. 1) can be obtained by setting the input reflection coefficient (S11) to the maximum and the forward transmission coefficient (S21) to the minimum in a passband. An insertion loss method deals directly with frequency responses and provides an elegant solution to the approximation problem. Today, most of microwave filter designs are done with the matlab based on an insertion loss method.

A design by insertion loss starts from a mathematical description of the overall desired response using approximation because ideal filter cannot be realized. An acceptable approximation of the response has a magnitude function with sufficiently small variation in a passband to be negligible and an attenuation that is sufficiently large in a stop band. Four classical solutions to the approximation are the Butterworth (maximally flat), Chebyshev (equal ripple in the passband), inverse Chebyshev (equal ripple in the stopband).

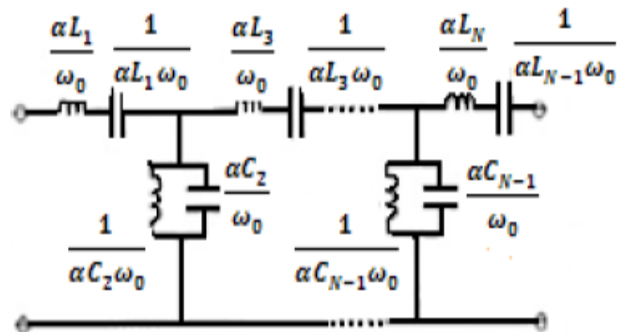

Fig 2. Generalize chebyshev band pass filter

The bandpass filter, which was derived from the lowpass prototype filter by introducing complementary elements and by producing shunt and series resonators. The alternating topology can be presented by using only one type of a resonator between inverters. These are basic

lowpass to bandpass transformations, and sometimes they lead to component values, which are not readily available or have excessive losses.

The topology of bandpass filter may vary by choosing different types of lowpass prototypes, but it is preferably to minimise numbers of inductors. It connects with high losses in inductors because quality factor is lower than Q of capacitors. Moreover, inductors, especially aircore ones, increase the size of filter in PCB[13].

3. Proposed model

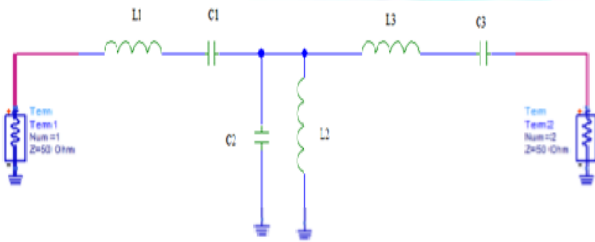

Fig:3 Third order generalized chebyshev band pass filter network

In this proposed model L1,C1 are series element and L2,C2 is shunt element. Value of the element is given below

Table 1: Component value of prototype lumped element

| Elements | Value |
|-------------|---------|
| $C_1=C_3$ | 0.0245 |
| C_2 | 45.8962 |
| $l_1 = l_3$ | 41.2634 |
| l_2 | 0.0219 |

The band pass operates in system impedance of 50Ω. The value of each inductor and capacitor can be calculated in 50Ω with center frequency 2 GHz

$$L'_r = \frac{Z_0 L_r}{w_c} \tag{1}$$

$$C'_r = \frac{C_r}{Z_0 w_c} \tag{2}$$

By the help of above equation the element value can be calculated as

Table 2: Component value of lumped element

| Elements | Value |
|-------------|-----------|
| $C_1 = C_3$ | 0.039pF |
| C_2 | 73.046pF |
| $l_1 = l_3$ | 164.182nH |

| | |
|-------|---------|
| l_2 | 0.087nH |
|-------|---------|

3.1 Flow chart of proposed model

The flow chart of proposed model is shown below

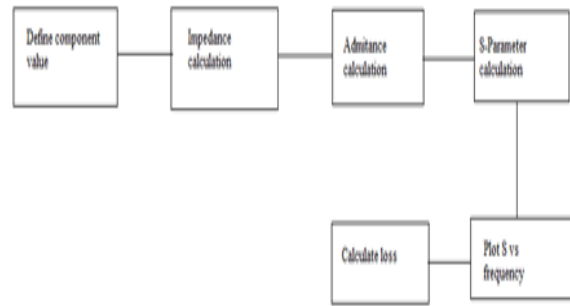

Fig:4 Flow chart of proposed model

In this proposed model firstly we define the component value then calculate impedance value. The value of S-Parameter can be calculated by help of impedance value and we can calculate insertion loss and return loss also.

4. Experimental results

4.1 Performance of proposed model

The value of inductance, capacitance and frequency are to be taken as initial values. Then by the help of Z-Parameter and S-Parameter can be calculated through Matlab code. Here we use Matlab software for the calculation of Parameter and to plot different graph.

Z-Parameter calculation

The formula for calculation of Z-Parameter is given below

$$Z_a = j * \omega * L_1 + \left(\frac{1}{j * \omega * C_1} \right) \tag{3}$$

$$Z_b = j * \omega * L_2 / (1 - \omega^2 * L_2 * C_2) \tag{4}$$

$$Z_{11} = Z_a + Z_b \tag{5}$$

$$Z_{21} = Z_b \tag{6}$$

4.1.2 S-Parameter calculation

The formula for calculation of S-Parameter is given below

$$S_{11} = \frac{((1-Z_0 * Y_{11})^2 + (Z_0^2 * Y_{21}^2))}{D} \tag{7}$$

$$S_{21} = \frac{-2 * Z_0 * Y_{21}}{D} \tag{8}$$

where

$$D = (1 + Z_0 * Y_{11})^2 - Z_0^2 * Y_{21}^2 \tag{9}$$

$$Z_0 = \sqrt{\frac{L_1}{C_2}}$$

$$Y_{11} = \frac{Z_{21}}{Z}$$

$$Y_{21} = -\frac{Z_{21}}{Z}$$

4.1.3 Calculation of insertion loss and return loss
The formula for calculation of insertion loss and return loss is given below

$$IL = -20 \cdot \log(S_{21}) \tag{10}$$

$$RL = -20 \cdot \log(S_{11}) \tag{11}$$

Calculated results is given below

Table 3: Calculated results

| Parameter | Frequency range (1GHz-5GHz) |
|------------------------|-----------------------------|
| Z_{11} (k Ω) | 1.032 |
| Z_{21} (k Ω) | .729 |
| S_{11} | -29.72 |
| S_{21} | -72.58 |
| Insertion loss(dB) | -42.9935 |
| Return loss(dB) | -92.6529 |

4.2 chebyshev band pass filter synthesis:

4.2.1 Input value of frequency band

we take input value of frequency band from 1GHz to 10 GHz. plot between S-Parameter and frequency for center frequency of 5 GHz is given below

By the help of above formula we can calculate the component value for different frequency. The component

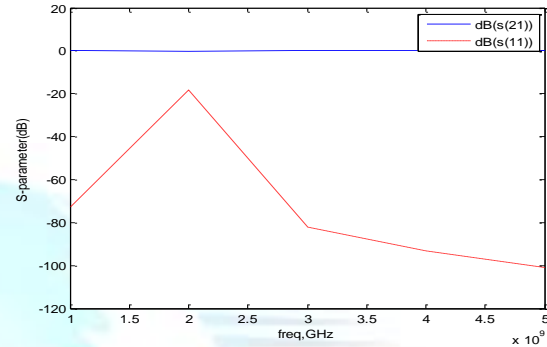

value for different frequency is shown below

Table 4: Component value for different frequency

| | 1 GHz | 3 GHz | 5 GHz |
|-------|-----------|-----------|-----------|
| l_1 | 164.182nH | 164.182nH | 164.182nH |
| l_2 | 0.347nH | 0.039nH | 0.014nH |
| c_1 | 0.154pF | 0.017pF | 0.006pF |
| c_2 | 73.046pF | 73.046pF | 73.046pF |
| IL | -42.9932 | -42.994 | -43.1716 |
| RL | -92.9050 | -92.1391 | -81.5603 |

Fig:5 Plot between S-Parameter and frequency

4.2.2 Calculation of filter component

the element value of chebyshev band pass filter can be calculated from equation (1) and equation (2)

$$L'_1 = \frac{50 \cdot 41.0634}{2 \cdot \pi \cdot 2 \cdot 10^9}$$

$$L'_2 = \frac{50 \cdot 0.0219}{2 \cdot \pi \cdot 2 \cdot 10^9}$$

$$C'_1 = \frac{0.0245}{50 \cdot 2 \cdot \pi \cdot 2 \cdot 10^9}$$

$$C'_2 = \frac{45.8962}{50 \cdot 2 \cdot \pi \cdot 2 \cdot 10^9}$$

4.2.3 Plot S-Parameter and frequency

The proposed model of chebyshev band pass filter for 2GHz is shown below.

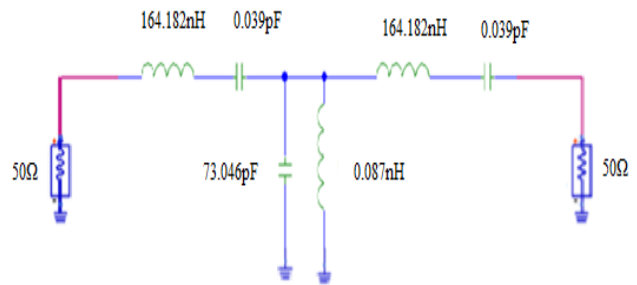

Fig:6 Chebyshev band pass filter network for 2 GHz frequency

Table 5: Calculated results

| Parameter | Frequency range (1GHz-10GHz) |
|-----------|------------------------------|
|-----------|------------------------------|

| | |
|--------------------|----------|
| $Z_{11}(k \Omega)$ | 10.32 |
| $Z_{21}(k \Omega)$ | .29 |
| S_{11} | -29.70 |
| S_{21} | -62.46 |
| Insertion loss(dB) | -43.1716 |
| Return loss(dB) | -81.5603 |

The plot between S-Parameter and frequency filter is shown below. When we applied the frequency range from 1 GHz to 10 GHz then we get notch at 5GHz. the return loss and insertion loss can be calculated by the graph.

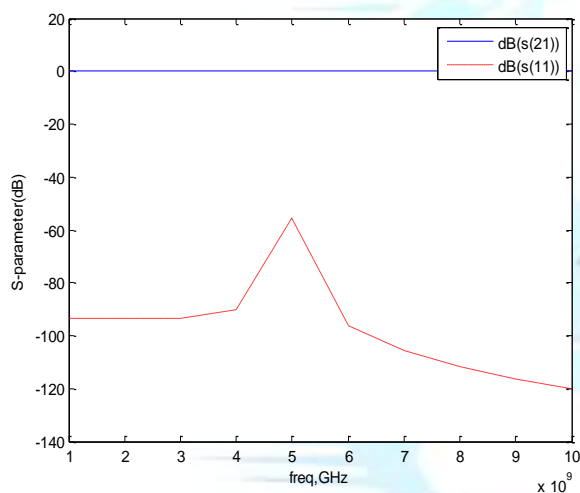

Fig:7 Plot between S-Parameter and frequency

5. Conclusion

Synthesis model of generalized chebyshev band pass filter for microwave frequency is designed successfully. In proposed model we calculate S-Parameter Insertion loss Return loss up to 10 GHz. This model can be implemented as a portable designer tool for particularly engineer working for microwave filter design. The main goal is to development sufficiently compact, low cost tunable filters with a quite narrow bandwidth using currently available lumped-element components and a PCB board technology. Filter design, different topologies and methods to tune bandpass filters were explored to choose the best suitable variant to comply with the required purpose. This design provides a good response on center frequency of 2 GHz with a return loss better than -60 dB and insertion loss better then -40dB.

References

- [1] Z. Zakaria, m. A. Mutalib, m. S. M. Isa, a. A. Mdisa, n. A. Zainuddin and w. Y. Sam” design of generalized chebyshev low pass filter with defected strip line structure (dss)” 2013 ieee symposium on wireless technology and algorithm september 22-25,2013 kuchingmalaysia
- [2] Z. Zakaria1, m. A. Mutalib2, m. S. Mohamad isa3, n. A. Zainuddin4” transformation of generalized chebyshevlowpass filter prototype to suspended stripline structure highpass filter for wideband communication systems” proceeding of the 2013 ieee international conference on rfid technologies and applications, 4 – 5 september, johorbahru, malaysia
- [3] Runqizhang, ” synthesis and design of wideband dual-band bandpass filters with controllable in-band ripple factor and dual-band isolation”ieee transactions on microwave theory and techniques, vol. 61, no. 5, may 2013
- [4] Robertogómez-garcía, “signal-interference stepped-impedance-line Microstrip filters and application to duplexers” ieee microwave and wireless components letters, vol. 21, no. 8, august 2011
- [5] Richard j. Cameron, ” advanced coupling matrix synthesis techniques for microwave filters”ieee transactions on microwave theory and techniques, vol. 51, no. 1, january 2003.
- [6] Z. Zakaria, b. H. Ahmad. Design of siwbandpass filter with 6 dboffset.ieeerf and microwave conference (rfm), pp.87-90, 2011.
- [7] Z. Zakaria, a. Sabah, w. Y. Sam. Design of low-loss coaxial cavity bandpass filter with post-manufacturing tuning capabilities, ieee symposium on business, engineering and industrial applications (isbeia), pp. 733 – 736, 2012.
- [8] Z. Zakaria, m. A. Mutalib, k. Jusoff, m. S. Mohamadisa, m. A. Othman, b. H. Ahmad, m. Z. A. Abd.aziz, and s. Suhaimi, “current developments of microwave filters for wideband applications,” world applied sciences journal, vol. 21, pp. 31–40, 2013.
- [9] L.-C. Tsai and C.-W.Hsue, “Dual-band bandpass filters using equallength coupled-serial-shunted lines and -transform technique,” IEEETrans. Microw. Theory Techn., vol. 52, no. 4, pp. 1111–1117, Apr. 2004.
- [10] S. Amari, F. Seyfert, and M. Bekheit, “Theory of coupled resonator microwave bandpass filters of arbitrary bandwidth,” IEEE Trans. Microw.Theory Techn., vol. 58, no. 8, pp. 2188–2203, Aug. 2010.
- [11] S. A. Aleyab, “A Novel Class of Generalized Chebyshev Low-Pass Prototype for Suspended Substrate

www.ijreat.org

Stripline Filters,” IEEE Transactions on Microwave Theory and Techniques, vol. 30, no. 9, pp. 1341–1347, 1982.

[12] I. Hunter, Theory and Design of Microwave Filters. London, United Kingdom: The Institution of Engineering and Technology, 2001.

[13] G.L. Matthaei, L. Young, E.M.T. Jones, 1980. *Microwave Filters, Impedance-Matching Networks, and Coupling Structures*. Dedham, Massachusetts: Artech House Inc.

[14] J. Uher and W. J. R. Hoefer, 1991. "Tunable microwave and millimeter-wave band-pass filters", *Microwave Theory and Techniques, IEEE Transactions on*, vol. 39, pp. 643-653.



www.ijreat.org

Published by: PIONEER RESEARCH & DEVELOPMENT GROUP (www.prdg.org)